



the most extensive range of products
IN THE WATER FILTRATION SECTOR



ATLAS FILTRI

The best way to improve your water. Made in Italy.

WORLD EDITION

A range of double and triple filter housings for 4,5" cartridges.

DP BIG DUO & DP BIG TRIO

TOTALLY NEW TO THE MARKET



EDITORIAL

Daniele Costantini
VICE-PRESIDENT OF ATLAS FILTRI

We'll never stop advertising who we are, we'll never pass up the opportunity to promote an Atlas Filtri product. Over the years, we've proved ourselves all across the board as a vibrant, proactive group. This is why we want people to see us as a benchmark for water treatment in Italy, Europe, Africa, Asia, Oceania and the Americas. Our technical experience in the realm of filtration and knowledge of the water treatment industry, not to mention our passion and commitment, set us apart the world over, making us a unique organization. These are the distinguishing traits of our group today and the reason we feel justified in viewing ourselves as a steering force behind the water treatment industry. Providing solutions every day, everywhere!



double & triple design & safety



Manifold housings are a must at Atlas Filtri and these products are actually the manufacturer's "landmark" everyone can identify in the market. Single, double and triple housings are available for all models in the range, as for the Plus 3P and Plus 2P housings, for DP housings and now also for DP BIG housings.

SANIC

WATER FILTERS WITH
ANTIMICROBIAL
TECHNOLOGY

Atlas Filtri's research and technology result in the production of filter housings and filter cartridges with Antimicrobial Product Protection4

NEW SERVICES ON THE BLOCKS FOR THE BENEFIT OF THE MARKETS



Always committed to providing updated training to customers on both technical and commercial aspects, Atlas Filtri has set up a new division of its own with dedicated resources to offer advanced courses, training, seminars on-site and on-line to improve knowledge in order to boost our partner's business23



A new division dedicated to customers who market water treatment units and plants, when installation, start-up and maintenance is a key to the business. It is also well connected with the Academy division, in order to provide customers the key to open the business when necessary23

Filter Housings for every needs!



Design & Production - Since its inception Atlas Filtri has always been committed to Research and Development, with the goal being to provide solutions for the widest range of applications. Through innovative Technical and Design solutions, the application of stringent production standards and a commitment to ever-improving quality, Atlas Filtri is able to offer a comprehensive range of filter housings.

INSIDE



A wide range of filter cartridges, for sediment filtration and water treatment, made with various filtering and treating media8 - 9

BIG! The Atlas way.2

Self-cleaning filters11

THE ITALIAN CONCEPT23

WORLD NEWS

BIG! The ATLAS way.

With DP BIG DUO & DP BIG TRIO housings Atlas Filtri brings its program to a “never before seen” level.

It is really something amazing, which only Atlas Filtri could go through. It has been a great project, now the “amazing” is ready for the market, with all safety and labour-saving that Atlas Filtri manifold housings can provide.

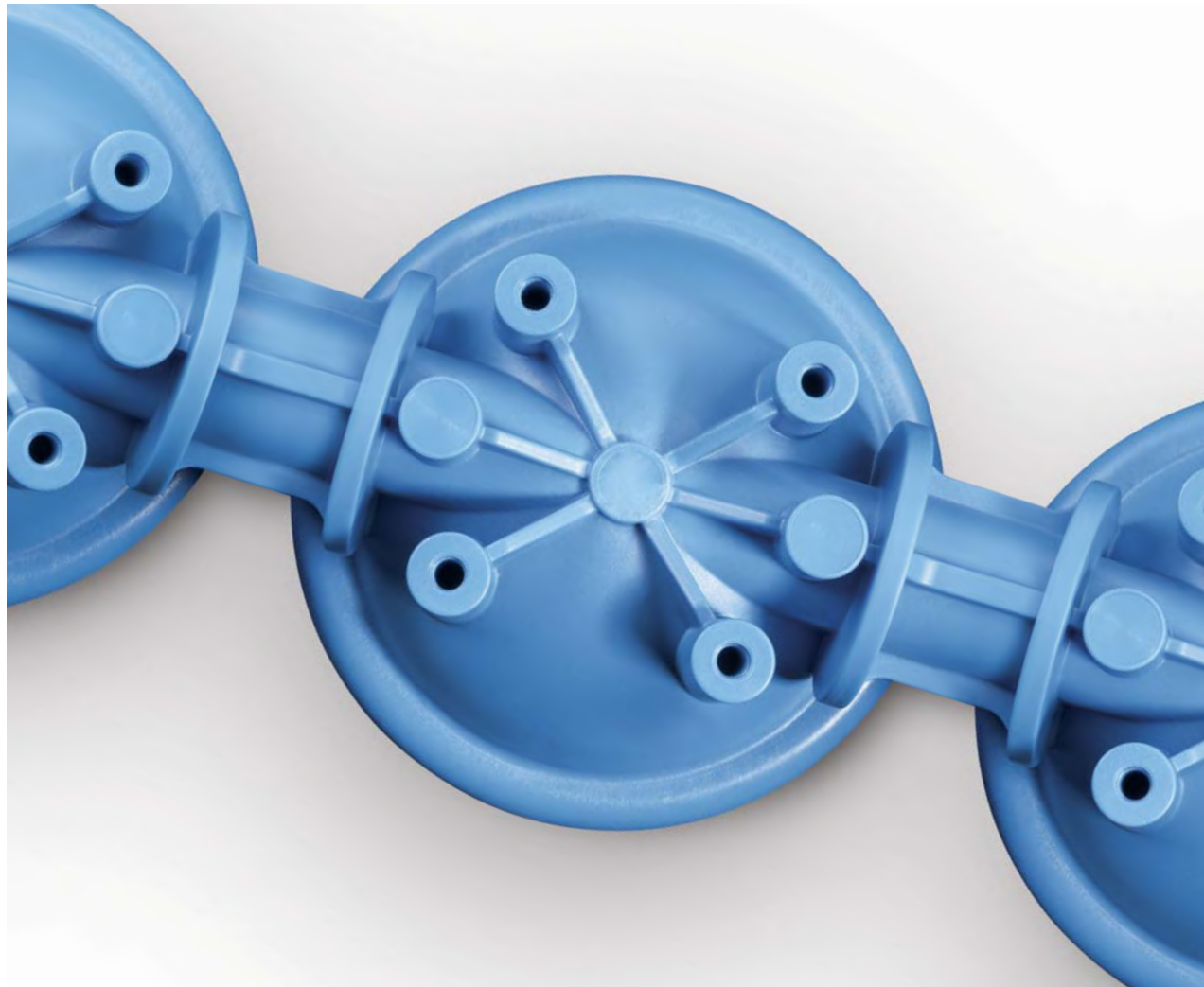

DP BIG DUO & DP BIG TRIO

A complete range of housings for 4,50" filter cartridges which will make your units for filtration in series so easy and safe you will enjoy from the installation. Filter housings in series designed with manifold head for double and triple filtration stages: that is a kind of “landmark” in Atlas Filtri’s landscape of products range. Markets are well aware of it, since all Atlas Filtri’s regular 2,50" housings are available that way. Yet, after the launch of DP BIG single housing - any expectation to get it double or triple? For Atlas Filtri it is a must!

Multiple filtration occurs often, since ever we have been offering solutions for safer housings and we always will. With Atlas Filtri manifold housings you have experienced exclusive products capable of capturing your market interest and secure the benefit of your customers.

You may imagine how it will be successful with the DP BIG range. A large, heavy housing is not that easy to be coupled with another one - outsource port unions, coupling labour and checking for leakages, often on installation site, running out of time... and then fix leaking before leaving the site or going back for repairs - those large housings are pretty heavy, not easy to hold all safe in place - it can be a nightmare. Well, now all that is solved.

Atlas Filtri is the one that makes manifold housings, double and triple; safer, easier, business booster.



PATENTED



WORLD NEWS

INTERVIEW

business & markets



Giannandrea Pozzer
SALES DIRECTOR
AT ATLAS FILTRI

Which are the major topics for the internationalisation development of a Company who is already exporting 95% of its turnover?

We are selling products, solutions, knowledge, but most importantly we are exporting "ourselves", our strong belief in 'Made in Italy' as a larger concept and not only as a logo on paper. In our opinion, to be international means "to be present" and this is the main focus in all our business plans.

You can support a market with frequent trips, installing profitable relationships and collecting direct experiences of local needs, but the step ahead to follow a long term strategy is the installation of a local organisation. Atlas Filtri is focussed in 5 continents with special attention to United States and Asia where there is a very important "work in progress" for new subsidiaries.

The choice of these two macro areas is related to different market analysis. The American market is the biggest volume market where all the top players are "at home", the Asian one is where "everything is happening". We want to be there and we will.

LUBRIKIT

Single-dose lubricant for housing o-ring to be used at the time of installation or maintenance.



Just apply the lubricant from its convenient, practical and safe doser and make the housing seal perfectly tight.

- LUBRIKIT is supplied as an accessory included with every DP BIG housing.
- LUBRIKIT is available as an accessory on demand for all other products.

SINGLE, DOUBLE AND TRIPLE

DP BIG housings, the newest, most comprehensive range of housings for 4,50" filter cartridges

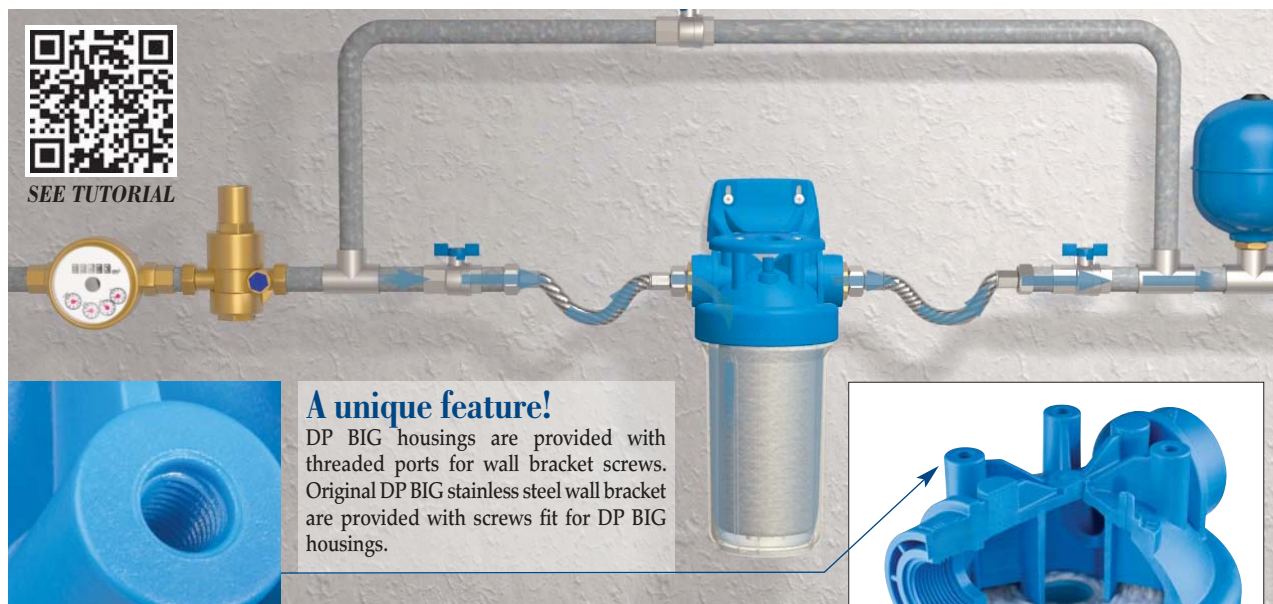

SEE TUTORIAL



A unique feature!

DP BIG housings are provided with threaded ports for wall bracket screws. Original DP BIG stainless steel wall bracket are provided with screws fit for DP BIG housings.



DP BIG FILTER HOUSINGS for BIG FILTER CARTRIDGES

Mono, Duo and Trio patented and registered models. Housings suitable for SX (DOE) filter cartridges with outer diameter from 4" to 4,50", heights at 10" and 20".

IN/OUT connections 1", 1 1/2" with plastic BSP or NPT threads.

Models with transparent (TS) or opaque (AB-blue) bowls. M models with 2 manometers.

S models with drain valve, provided with a funnel to protect potable water from back-flow, in compliance with UNI EN 1717 - 11/2002.

Accessory included: Lubrikit.

Accessories on demand: spanner, metal wall bracket,

KIT AUTO (discharge automation kit).

Main materials: reinforced PP, PET.



DP BIG 10" TS

DP BIG 10" AB

DP BIG 10" S M TS

DP BIG 20" AB

DP BIG 20" TS

THE BIG FILTER CARTRIDGES



CPP BIG

FA BIG

CB EC BIG



CS BIG

TS BIG

SA BIG

RA BIG

NEW · NEW · NEW

The range of BIG filter cartridges (outer diameter 110 mm - 4,50"), now implemented with new models:

CS BIG - 10" and 20" pleated paper, filter rate 25 micron.

TS BIG - 10" and 20" pleated polyester fabric, filter rate 50 micron.

SA BIG - 10" and 20" pleated stainless steel washable net, filter rate 50 micron.

RA BIG - 10" and 20" stainless steel washable net, filter rate 70 micron.

CPP BIG - 10" and 20" polypropylene melt-blown, filter rate from 5 to 25 micron.

FA BIG - 10" and 20" polypropylene string wound, filter rate from 1 to 100 micron.

CB EC BIG - 10" and 20" carbon block, CTO, VOC, Pb, Cyst models, filter rate from 1 to 10 micron.

ANTIMICROBIAL TECHNOLOGY

SANIC
WATER FILTERS WITH
ANTIMICROBIAL
TECHNOLOGY

Atlas Filtri research and technology result in the production of filter housings and cartridges with Antimicrobial Product Protection.

The Antimicrobial protection is performed by a proprietary technology which makes the antimicrobial agent included in the plastic matrix. Stain and odor causing bacteria are not allowed to grow on the housing surfaces, even in still water. Sanic housings in combination with Sanic filter cartridges are the best solution for filtration of drinking water.

PATENTED

DP BIG SANIC

with the **ADVANTAGE** of Antimicrobial Technology



DP BIG 10" SANIC



DP BIG 10" SANIC BG



DP BIG 10" DUO SANIC



DP BIG 10" TRIO SANIC BG

Mono, Duo and Trio patented and registered housings with Antimicrobial Product Protection technology, designed to fit to FA BIG wound polypropylene filter cartridges with Antimicrobial Product Protection.

IN/OUT connections 1", 1 1/2" with plastic BSP or NPT threads. Cartridge heights 10", 20". Models with transparent (SANIC) and with opaque (SANIC BG-grey) bowls. Accessory included: Lubrikit. Accessories on demand: spanner, metal wall bracket. Main materials: reinforced PP with antimicrobial technology, PET with antimicrobial technology.

SEDIMENT CARTRIDGES

Sediment filter cartridges provided with Antimicrobial Product Protection technology. Sanic cartridges are designed to work in combination with Sanic filter housings, yet can provide antimicrobial product protection with every filter housing.

- CPP SANIC, PP melt-blown cartridges with heights from 4" to 50", filter rates from 1 to 50 micron, outer diameter at 61 mm (2,40"), SX and BX configurations.
- FA SANIC, wound PP thread with heights from 4" to 40", filter rates from 1 to 100 micron, outer diameter at 45 mm (1,77"), 56 mm (2,20") 61 mm (2,40") and 110 mm (4,50") for DP BIG SANIC and DP BIG housings, SX and BX configurations.



FA SX

FA BX

FA BIG

CPP SX

CPP BX



PLUS 3P SANIC

Single, Duplex and Triplex housings with Antimicrobial Product Protection technology, for cartridges with standard SX flat seals (DOE) and for cartridges with BX quick-fit double o-ring.

IN/OUT connections 1/2", 3/4", 1" with brass or plastic BSP threads; models with NPT plastic threads 3/4", 1". Range of models: Medium, Junior, Senior, Master for cartridge heights 5", 7", 10", 20". Models with transparent (SANIC) and with opaque (SANIC BG-grey) bowls. Accessories included: spanner, wall brackets. Accessory on demand: Lubrikit. Main materials: reinforced PP, PET with antimicrobial technology.

DP SANIC

Mono, Duo and Trio patented and registered housings with Antimicrobial Product Protection technology. Housings suitable for cartridges with both standard SX flat seals (DOE) and BX quick-fit double o-ring end cap. Housings provided with Filter-Fit: special centering device for SX cartridges.

IN/OUT connections 1/4", 3/8", 1/2", 3/4", 1", with brass or plastic BSP threads; models with NPT plastic threads 1/4", 3/4", 1". Models with transparent (SANIC) and with opaque (SANIC BG-grey) bowls. Cartridge heights 5", 7", 10", 20". Accessories included: spanner, wall brackets, Filter-Fit. Accessory on demand: Lubrikit. Main materials: reinforced PP, PET with antimicrobial technology.

HIGHLIGHTS

ATLAS FILTRI EQUALS INNOVATION IN MATERIALS



«Offering assurance and efficiency, starting with the raw materials»

Atlas Filtri, always stays one step ahead, starting with materials. Every day giving extra point of difference by using new, improved and innovative materials, such as PET, to further build on Atlas Filtri's longstanding reputation for safety.

As part of this process, Atlas Filtri is forever testing new raw materials and looking into new manufacturing processes to enhance and further develop the filter's properties. The strength of the Atlas Filtri products lies in this successful merging of innovation, top-quality materials and an environmental conscience.

MP CONNECTIONS: installation made easy!

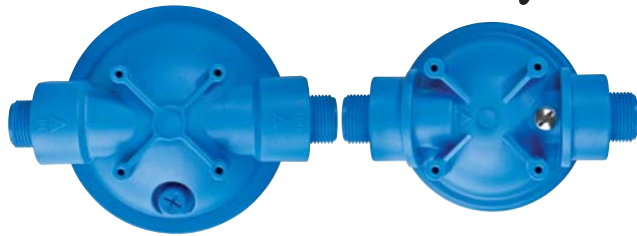

The MALE IN/OUT THREADED version of Atlas Filtri housings and systems is now available as MP version of PLUS and DP housings, HYDRA self-cleaning filters, DOSAFOS polyphosphate dosing systems. **MP connections make it possible to connect products directly to pipes: no need for nipples, get the installation easier and safer.**



MICRO FILTER: the smallest

Designed for applications with cleaners, pressure-washers, micro-irrigation.

Dimensions mm 75 x 50 x 65 h.

IN/OUT connections 3/8" with plastic BSP threads. GL model with plastic strainer, filtration 1000 micron.

RAM-C model with stainless steel net, filtration 300 micron (available on demand: 100, 200, 400, 500 micron).

Main materials: PP, reinforced PP, SAN, stainless steel AISI 304.



GL CARTRIDGE
POLYPROPYLENE



RAM-C CARTRIDGE
STAINLESS STEEL NET
AISI 304



INTERVIEW

research & development



Damiano Moro
TECHNICAL DIRECTOR
AT ATLAS FILTRI

Atlas Filtri has been manufacturing in Italy and marketing worldwide for 40 years; there are key reasons behind such a long story, which rely on continuous improvements on different aspects: strategies, production and logistics.

By using innovative technologies and design, by applying severe production standards with commitment to total quality, Atlas Filtri is continuously engaged in Research and Development, through a dedicated team of skilled professionals, the target being products improvement on efficiency, reliability and durability.

This approach means going continuously through the research for new, more performing raw materials, the exploitation of new molding methods and the implementation of fully robotized production lines - yet open and flexible. Then all this must be reflected to all products in our range, which is one of the largest and most complete in the market, keeping the production also ready for specific requirements out of the standard.

As water is the most precious resource that nations have to manage and protect, Atlas Filtri's mission is to offer the market the most up-to-date products and give consumers reliable solutions through innovation, with high attention to the environment.

These goals can be achieved only by teaming up every day, with all of us engaged in problem solving and in sharing successes. The growth of our Company is the result of the strong commitment which keeps anyone of us involved from research and development, to design, to production and marketing. At Atlas Filtri, our passion and enthusiasm are channelled into continuous research. This is where ideas are turned into designs and devices that boost our level of quality and the user friendliness of our filters.

We're working on the European Commission-funded project WATER "Winning Applications of nanoTechnology for Resolutive hydropurification" - coordinated by Italy's national research council (CNR) - alongside prestigious Italian and European partners from the world of scientific research, looking for innovative ways to apply nanotechnology to the issue of water purification.

Role in WATER project:

Atlas Filtri supports CNR for the technology transfer and the potential of effective application of the innovation produced by the WATER action.

Atlas Filtri studies with CNR the reliability of prototypes.

water

The National Research Council (CNR) is the largest public research institution in Italy. Within it, the Institute of Microelectronics and Microsystems (IMM) has been founded in 2004 and it is distributed over 7 units. Today it counts about 120 scientists and 70 collaborators (technical and administrative personnel). The research group responsible for the WATER project is composed of 10 researchers of IMM-Catania and 5 professors from the Department of Physics of the University of Catania associated to CNR.

PARTNERS: University of Oslo (Centre for Materials Science and Nanotechnology), **Centre National de la Recherche Scientifique** (Centre d'Elaboration de Matériaux et d'Etudes Structurales), **Consejo Superior de Investigaciones Científicas** (Pyrenean Institute of Ecology), **University of Sheffield** (Pennine Water Group), **Research Institute for Water and Waste Water Technology** (-Versuchs- und Lehranstalt für Brauerei in Berlin), **University of Catania** (Center for Professional Development, Innovation and Technology Transfer), **Municipality of Acì Castello**, **Marine Protected Area of the Cyclops Islands.**

RANGE OF PRODUCTS

PLUS 3P FILTER HOUSINGS



SEE TUTORIAL

Single, Duplex and Triplex housings for cartridges with standard SX flat seals (DOE) and for cartridges with BX and CX quick-fit double o-ring.

IN/OUT connections 1/2", 3/4", 1", 1 1/4", 1 1/2", with brass or plastic BSP threads; models with NPT plastic threads 3/4", 1". Range of models: Medium, Junior, Senior, Master for cartridge heights 5", 7", 10", 20".

Models with transparent (TS) or opaque (AB-blue) bowls.

M models with 2 manometers.

S models Senior (10") and Master (20") with drain valve, provided with a funnel to protect potable water from back-flow, in compliance with UNI EN 1717 - 11/2002.

MP models with plastic male IN/OUT connections BSP threads.

For cartridges with BX and CX quick-fit double o-ring end cap.

Accessories on demand: spanner, wall brackets, diffuser tubes, brass and plastic nipples, KIT AUTO (discharge automation kit), Lubrikit.

Main materials: reinforced PP, PET.



SENIOR PLUS S M 3P TS



SENIOR PLUS 3P TS



SENIOR PLUS 3P AB



SENIOR DUPLEX PLUS 3P TS



SENIOR TRIPLEX PLUS 3P TS



SENIOR TRIPLEX PLUS 3P AB



SENIOR PLUS 2P AS

SENIOR TRIPLEX PLUS 2P AS

PLUS 2P FILTER HOUSINGS

Single, Duplex and Triplex housings for cartridges with standard SX flat seals (DOE).

IN/OUT connections 1/2", 3/4", 1", with brass or plastic BSP threads; models with NPT plastic threads 3/4", 1".

Range of models: Cadet, Junior, Senior for cartridge heights 4", 7", 10".

Models with transparent (AS) or opaque (AB-blue) bowls.

M models with 2 manometers.

MP models with plastic male IN/OUT connections BSP threads.

Accessories on demand: spanner, wall brackets, diffuser tubes, brass and plastic nipples, Lubrikit.

Main materials: reinforced PP, SAN.

MIGNON PLUS FILTER HOUSINGS



MIGNON L 2P AS

MIGNON S 2P AB

MIGNON SL 3P AS

Single and Duplex housings for Mignon cartridges with height 5" M - outer diameter 45 mm (1,77") inner diameter 18 mm (0,71") - with standard SX flat seals (DOE).

IN/OUT connections 1/2", 3/4" with brass BSP threads.

Single and Duplex models with -L- in-line connections.

Single models with -S- 90° connections and -SL- 3 ports heads connections.

3P PLUS and 2P PLUS models.

Models with transparent (AS) or opaque (AB-blue) bowls.

Accessories on demand: spanner, wall bracket Duplex, diffuser tube, brass and plastic nipples, Lubrikit.

Main materials: reinforced PP, SAN.

RANGE OF PRODUCTS

PROFESSIONAL HOUSINGS

K DP - FX AF - XX

K DP housings with brass head and PET bowl.

IN/OUT connections 3/4", 1", 1 1/2", 2" with BSP threads.
 Cartridge heights 5", 7", 10", 20" with BX and CX quick-fit double o-ring end cap. M models with 2 manometers.
 S models 10" and 20" with drain valve, provided with a funnel to protect potable water from back-flow, in compliance with UNI EN 1717 - 11/2002.

Accessories on demand: spanner, wall bracket, brass nipples, KIT AUTO (discharge automation kit), Lubrikit.

FX AF housings with brass head and stainless steel bowl.

IN/OUT connections 3/4", 1", 1 1/2", 2" with BSP threads.
 Cartridge heights 10", 20" with BX and CX quick-fit double o-ring end cap. Accessories on demand: wall bracket, brass nipples, Lubrikit.

XX full stainless steel housings.

IN/OUT connections 3/4", 1", 1 1/2" with BSP threads.
 Accessories on demand: wall bracket, Lubrikit.
 Cartridge heights 10" with standard SX flat seals (DOE) and with special CX-S end cap.



PP 3P FILTER HOUSINGS

Single and Duplex housings for cartridges with standard SX flat seals (DOE).

IN/OUT connections 1/2", 3/4", 1", with plastic BSP threads.
 Range of models: Mignon, Medium, Junior, Senior, Master, for cartridge heights 5" Mignon, 5", 7", 10", 20". V models with Viton o-rings. Accessories on demand: spanner, wall brackets, Lubrikit.
 Main materials: PP.

PLUS HOT 3P filter housings



for the filtration of HOT WATER

Single housings applicable for hot water with special FA-HOT wound polypropylene cartridges, with CPP polypropylene melt-blown cartridges and with RA stainless steel net cartridges.

For cartridges with standard SX flat seals (DOE).
 IN/OUT connections 1/2", 3/4", 1", with plastic BSP threads; models with NPT plastic threads 3/4", 1".

Range of models: Medium, Junior, Senior, Master for cartridge heights 5", 7", 10", 20".

HOT-S models Senior (10") and Master (20") with drain valve, provided with a funnel to protect potable water from back-flow, in compliance with UNI EN 1717-11/2002. For cartridges with BX quick-fit double o-ring end cap.

Accessories on demand: spanner, wall bracket, KIT AUTO (discharge automation kit), Lubrikit.

Main materials: reinforced polyamide.

DRAIN FUNNEL
 Back-flow preventing device
 UNI EN 1717-11/2002

ACADEMY

HOW TO INSTALL?

1. Municipal water mains
2. Pressure reducer
3. Anti-water hammer device
4. Other utilities
5. Filter unit of any model

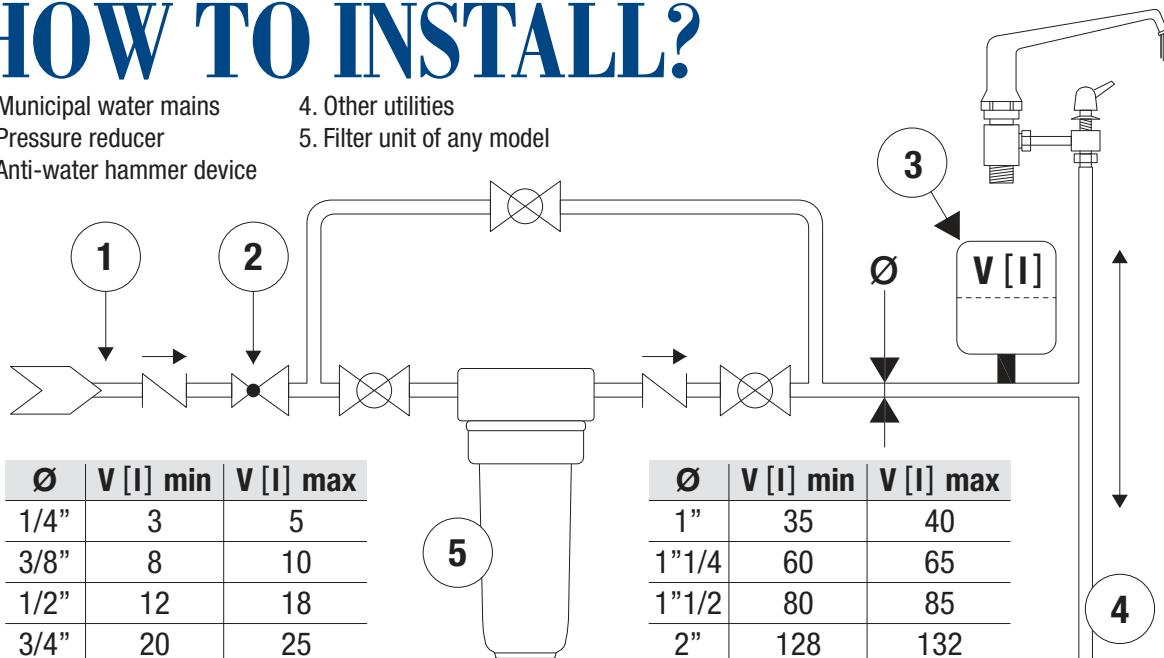

Ø	V [l] min	V [l] max
1/4"	3	5
3/8"	8	10
1/2"	12	18
3/4"	20	25

Ø	V [l] min	V [l] max
1"	35	40
1 1/4"	60	65
1 1/2"	80	85
2"	128	132

HUMOR

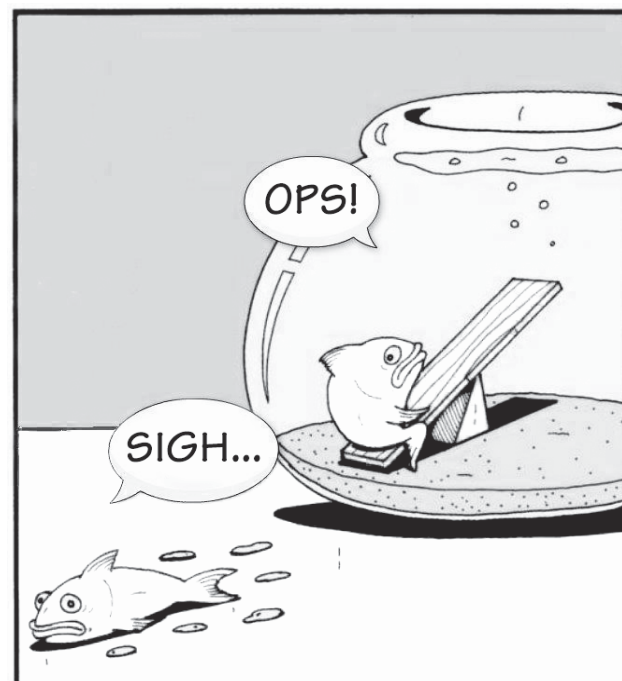

RANGE OF PRODUCTS

Water Filter Cartridges

A wide range of filter cartridges, for mechanical filtration and water treatment, made with various filtering and treating media.

- SX models with standard DOE flat seals, suitable to Atlas Filtri SX and DP housings and to major standard housings.
- BX models with 45 mm double o-ring end cap for exclusive use with Atlas Filtri housings 3P Plus BX, DP and K DP.
- CX models with 57 mm double o-ring end cap for exclusive use with Atlas Filtri housings 3P Plus CX and K DP.
- Models with standard outer diameter 61 mm (2,40"), heights: 4", 5", 7", 10", 20", 30", 40".
- Models 5"M Mignon (for Mignon housings) with outer diameter 45 mm (1,77") inner diameter 18 mm (0,71").
- Models BIG (for DP BIG housings) with outer diameter 110 mm (4,50"), heights 10" and 20".

Accessories on demand: Filter-Fit special centering device for SX cartridges applicable for DP housings; containing sponge.



SX Standard double open end (DOE) configuration with flat seals. All SX cartridges are provided with the new grey flat seals with Antimicrobial Product Protection technology.



BX Quick-fit configuration with 45 mm double o-ring end cap.



CX Quick-fit configuration with 57 mm double o-ring end cap.

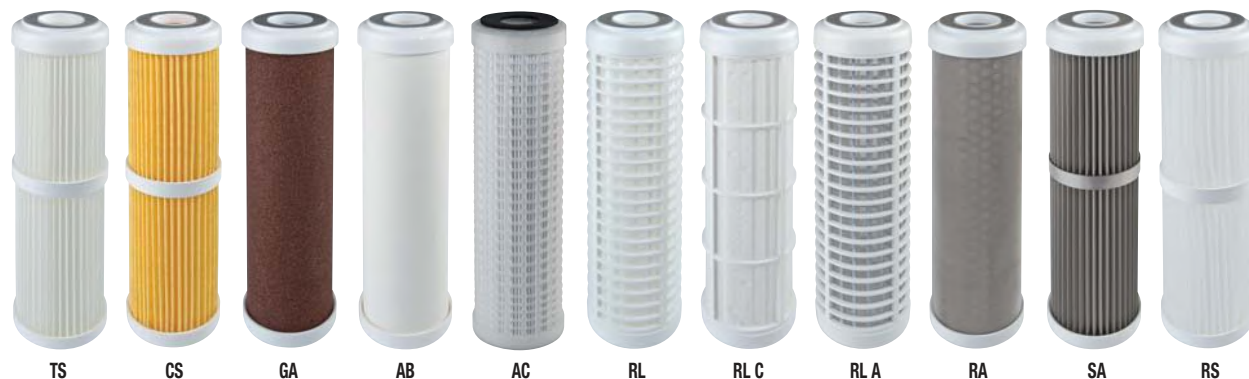

SEDIMENT FILTRATION

Filter nets (washable cartridges)

- RL polyester net, filter rate 50 micron, heights 4", 5"M, 5", 7", 10", 20". SX, BX, CX models.
- RL A polypropylene frame/stainless steel net AISI 316 filter rate 70 micron, heights 10", 20". SX, BX, CX models.
- RL C polyester net easy-clean, filter rate 50 micron, heights 10", 20". SX, BX, CX models.
- RS pleated polypropylene net, filter rate 50 micron, heights 4", 5", 7", 10", 20". SX, BX, CX models.
- RA stainless steel net AISI 304 (RA-C) or AISI 316 (RA-A), filter rate 70 micron, heights 4", 5"M, 5", 7", 10", 20". SX, BX, CX models.
- SA pleated stainless steel net AISI 304 (SA-C) or AISI 316 (SA-A), filter rates 50 micron, heights 4", 5"M, 5", 7", 10", 20". SX, BX, CX models.

Filtration in depth (disposable cartridges)

- TS pleated polyester felt, filter rate 50 micron, heights 4", 5"M, 5", 7", 10", 20". SX, BX, CX models.
- CS pleated paper, filter rate 25 micron, heights 4", 5"M, 5", 7", 10", 20". SX, BX, CX models.
- GA quartzite block, filter rate 10 micron, heights 4", 5", 7", 10", 20". SX, BX models.
- AB ceramic, filter rate 0,45 micron, heights 4", 5"M, 5", 7", 10", 10"V (outer diameter 50 mm - 1,77"), 20". SX, BX models.
- AC pleated polyester-borosilicate or polypropylene micro-filtration membranes with outer extruded frame, filter rate 0,2 and 0,45 micron, heights 10", 20". SX, BX models.
- AC-K pleated polyester-borosilicate or polypropylene micro-filtration membranes with outer moulded frame, filter rate from 0,2 to 55 micron, heights 10", 20", 30", 40". SX, BX models, (and other end caps configurations).



MELT BLOWN

MELT-BLOWN polypropylene cartridges with benefits in high efficiency filtration:

- Standardization of the production.
- Thermal insulation.
- Certified raw materials.
- Full automation of the production line.
- No direct human intervention.
- Highest productivity.
- Quick delivery.
- Flexibility of the production line.
- Customized and OEM products.

CPP melt-blown smooth, filter rates 1, 5, 10, 25, 50 micron, heights 4", 5", 7", 10", 20", 30", 40", 50". SX, BX CX models (and other end caps configurations).

Outer diameter: 61 mm (2,40").

- CPP-IC models with inner core.
- CPP-IC/E models with inner core and end caps.

PP melt-blown grooved, filter rates 1, 5, 10, 25, 50 micron, heights 10", 20". SX, BX CX models (and other end caps configurations).

Outer diameter: 61 mm (2,40").

FA - STRING WOUND

Filter cartridges made with polypropylene thread wound on a polypropylene inner core, available in a variety of filter rates, heights, diameters and configurations.

FA cartridges are made to comply with the most stringent regulations for applications in drinking water and are ACS (Attestation de Conformité Sanitaire, France) certified.

- FA Mignon: outer diameter 45 mm (1,77") inner diameter 18 mm (0,71"), height 5"M. Filter rates 5, 10, 25, 50, 100 micron. SX models.
- FA-R series: outer diameter 56 mm (2,20") inner diameter 28 mm (1,10"), height 10". Filter rates 5, 10, 25, 50 micron. SX models.
- FA series: outer diameter 61 mm (2,40") inner diameter 28 mm (1,10"), heights 4", 5", 7", 10", 20", 30", 40". Filter rates 1, 5, 10, 25, 50, 100 micron. SX BX, CX models (and other end caps configurations).
- FA BIG series: outer diameter 110 mm (4,50") inner diameter 28 mm

(1,10"), heights 10" and 20". Filter rates 1, 5, 10, 25, 50, 100 micron. Suitable for DP BIG housings.

- FA BIG MULTI-LAYER series: outer diameter 110 mm (4,50") inner diameter 28 mm (1,10"), heights 10" and 20".

Gradient dual-layer filter rates 10-1, 25-1, 50-5, 50-10, 100-25, 100-50 micron. Suitable for DP BIG housings.

for Hot Water...

FA HOT - STRING WOUND

Filter cartridges made with polypropylene thread wound on a special reinforced-polypropylene inner core, suitable to PLUS HOT 3P housings, applicable for the filtration of hot water.

outer diameter 61 mm (2,40") inner diameter 28 mm (1,10"), heights 5", 7", 10", 20". Filter rates 1, 5, 10, 25, 50, 100 micron.



RANGE OF PRODUCTS



Water Treatment



Extensive range of filter cartridges for every application in water treatment, made with the most appropriate media. Cartridge height available from 4" to 20", filter rate available from 0.2 to 50 micron. Custom made heights, filter rates and special media available on minimum quantity.

GAC chlorine, taste, odor reduction

LA with coconut shell GAC. Heights 5"M, 5", 7", 10", 20". SX, BX models.
 FA CA - polypropylene wound thread filter rates 5, 10, 25, 50, 100 micron with coconut shell GAC. Heights 5", 7", 10". SX, BX models.
 CA - polypropylene melt-blown filter rate 25 micron with coconut shell GAC. Heights 5"M, 4", 5", 7", 10", 20". SX, BX models.
 BT CPP LA - polypropylene melt-blown filter rates 5, 25 micron with coconut shell GAC. Heights 10", 20". SX, BX models.

CARBON BLOCK chlorine, taste, odor reduction

CA SE - carbon block filter rates 0,3, 1, 5 micron. Heights 4", 5", 7", 10". SX, BX models.
 CA SE HF - carbon block, hollow fibre membranes filter rates 0,15, 0,02 micron. Heights 10", 20". BX models.
 CB EC - carbon block filters with outer fleece and net, featuring eco-claim for the reduction of CO₂ release in atmosphere. Filter rates 1, 5, 10 micron. Heights 5", 7", 10", 20". SX models.

POLYPHOSPHATE anti-scale, anti-corrosion

HA with polyphosphate. Heights 5"M, 5", 7", 10", 20". SX, BX models.

BT CPP HA - polypropylene melt-blown filter rates 5, 25 micron with polyphosphate. Heights 10", 20". SX, BX models.
 BT RL HA - polyester washable net filter rate 50 micron with polyphosphate. Heights 5"M, 5", 7", 10", 20". SX, BX models.
 FA HA - wound PP thread filter rates 5, 10, 25, 50, 100 micron with polyphosphate. Heights 5", 7", 10". SX, BX models.
 CPP HA - melt-blown PP filter rates 5, 25 micron with polyphosphate. Heights 5"M, 10", 20". SX, BX models.

IONIC EXCHANGE RESINS

QA CF - strong cationic resin for water softening. Heights 5", 7", 10", 20". SX, BX models.
 QA AF - strong anionic resin for the reduction of nitrates. Heights 5", 7", 10", 20". SX, BX models.
 QA LM - mixed bed of anionic and cationic resin for demineralization, with colour change at resin depletion. Heights 5", 7", 10", 20". SX, BX models.

FILLABLE CARTRIDGES

P - Empty containers for filling with water treatment media. Heights 5"M, 5", 7", 10", 20". SX, BX models.

ACADEMY

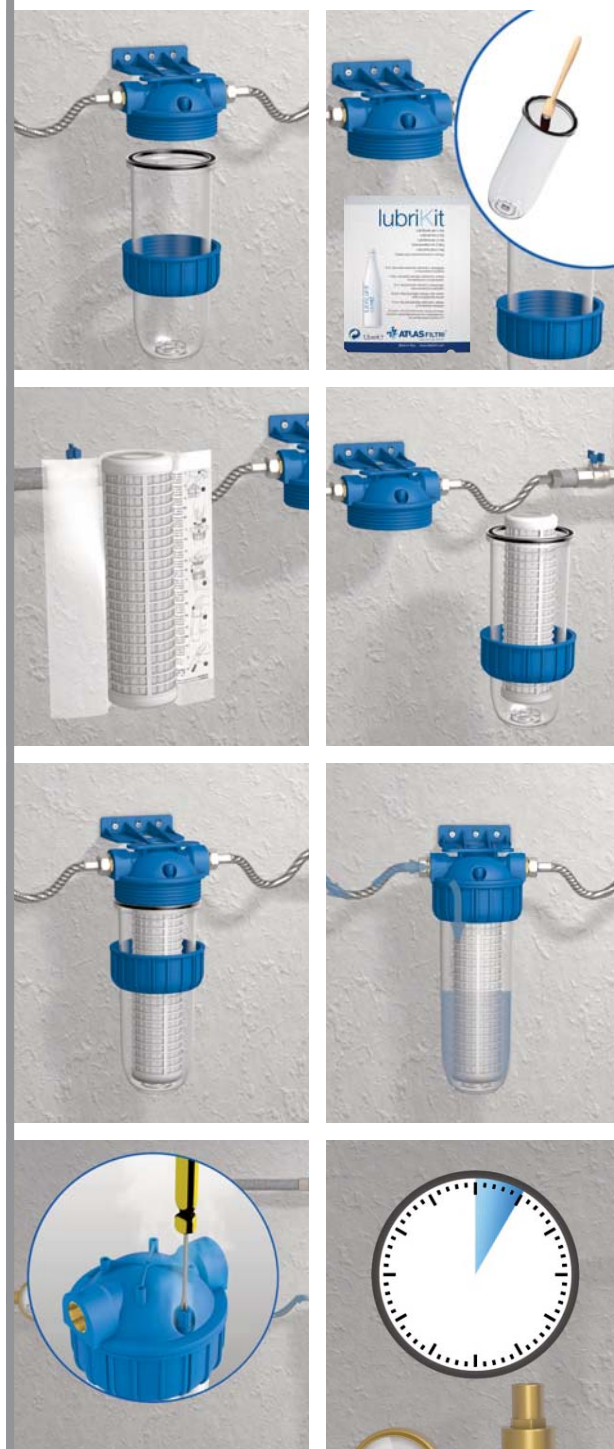
**Operations for Filter Cartridge replacement**

The average life of a filter cartridge varies depending on use, network and piping conditions, pressure, etc. In general, changes in taste, odor or color in the water indicate that the cartridge should be replaced.

Always use original ATLAS FILTRI cartridges.

- Before opening the filter housing turn-off the water main and place a tray under the system to catch any water spilling during the removal of the filter cartridge.
- Release the pressure from the product by un-screwing the vent-valve of the head.
- Open the housing unscrewing the housing.
- Remove the used cartridge.
- Wipe clean the filter housing with cold water and a soft sponge.
- Open the new cartridge wrap and discard wrap.
- Insert the new cartridge and place it into the housing.
- Tighten the housing bowl to housing's head using original wrench. Do not over-tighten.
- Turn-on the water main.
- Slowly turn on the water supply.
- Wait for air purge from the vent-valve, then turn and tighten the vent-valve.
- Let the water flow a few minutes before use.

RANGE OF PRODUCTS

THANK YOU RAIN!



SEE TUTORIAL

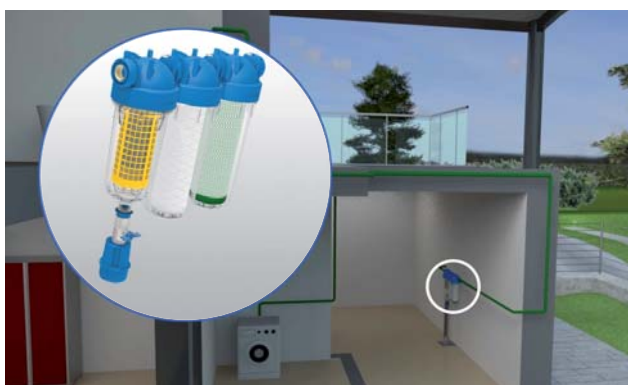

HYDRA RAINMASTER

Exclusive DUO and TRIO multi-stage filters, provided with a self-cleaning pre-filter plus post-filtration and treatment cartridges for dual or triple stage, especially designed for the filtration and treatment of rainwater.

HYDRA RAINMASTER
TRIO CB ECHYDRA RAINMASTER
TRIO LAHYDRA RAINMASTER
DUO CB ECHYDRA RAINMASTER
DUO LA

Self-cleaning pre-filter with back-wash, and exclusive filter cartridges:

- RAH stainless steel net cartridge at 90 micron; RLH plastic net cartridge at 90 micron; RSH pleated plastic net cartridge at 50 micron.
- LA models provided with GAC post-carbon cartridge, designed for high performance in clearing and odour reduction. Max flow rate 2800 l/h at 3 bar.
- CB EC models provided with post-carbon block cartridge, designed for high water flow and low pressure drop. Max flow rate 5500 l/h at 3 bar.

Secondary stage on TRIO models provided with polypropylene fine filter cartridge at 5 micron.

Models for 10" cartridges, IN/OUT connections 1/2", 3/4", 1" with brass or plastic BSP threads; models with NPT plastic threads 3/4", 1". Housings provided with Filter-Fit: special centering device for SX cartridges.

All models provided with a drain funnel to protect potable water from back-flow, in compliance with UNI EN 1717-11/2002.

Accessory included: Filter-Fit.

Accessories on demand: brass and plastic nipples, spanner, wall brackets, KIT AUTO (discharge automation kit), Lubrikit.

Main materials: reinforced PP, PET.

RANGE OF PRODUCTS

HYDRA self-cleaning filters

Self-cleaning filters with back-wash and exclusive filter cartridges:

- RAH models with stainless steel net cartridge at 90 micron.
 - RLH models with plastic net cartridge at 90 micron.
 - RSH models with pleated plastic net cartridge at 50 micron.
- IN/OUT connections 1/2", 3/4", 1", 1-1/4", 1-1/2" with brass or plastic BSP threads; models with NPT plastic threads 3/4", 1". Flow rates from 3000 to 10000 l/h.
- M models with 2 manometers.
- MP models with plastic male IN/OUT connections BSP threads.
- HYDRA HOT self-cleaning filters applicable for hot water filtration with dedicated cartridge RAH HOT.
- HYDRA K DP self-cleaning filters with brass head.
- All models provided with a drain funnel to protect potable water from back-flow, in compliance with UNI EN 1717-11/2002.
- Accessories included: spanner, wall bracket.
- Accessories on demand: brass and plastic nipples, KIT AUTO

(discharge automation kit), Lubrikit.
Main materials: reinforced PP, PET.



Kit Auto
DISCHARGE AUTOMATION KIT
Programmable kit with electro-valve for the full automation of discharge and self-cleaning operations.

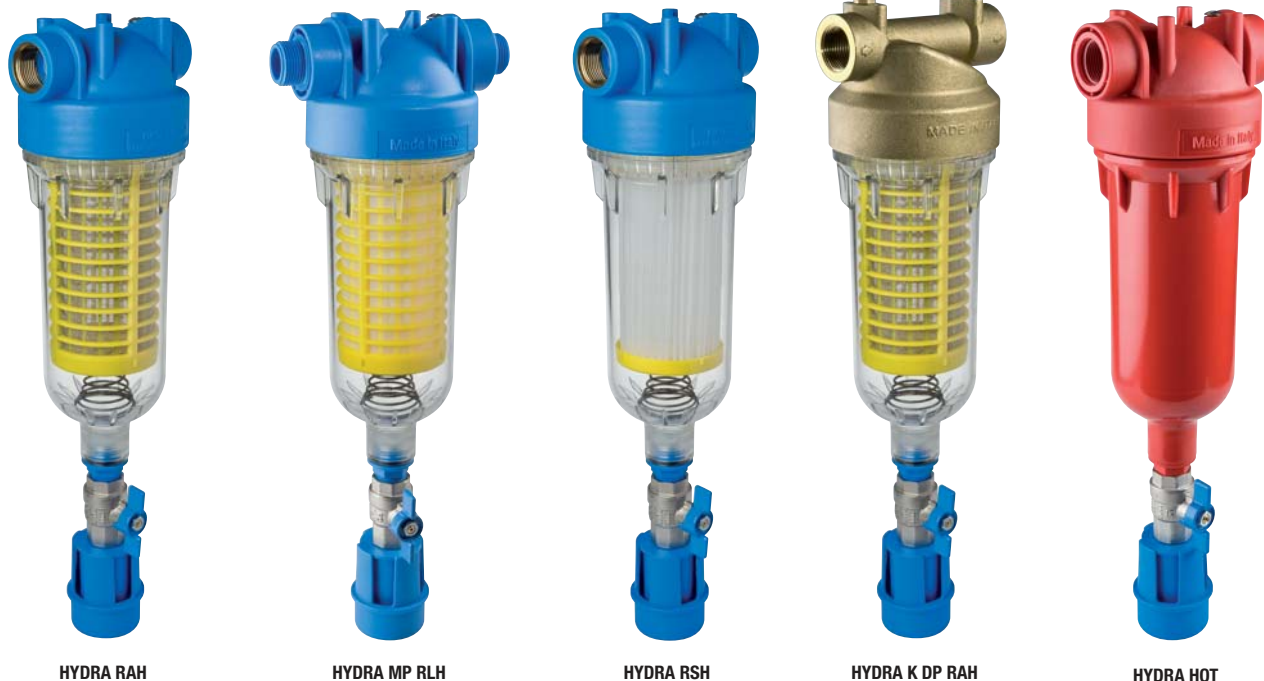

HYDRA RAH HYDRA MP RLH HYDRA RSH HYDRA K DP RAH HYDRA HOT

HYDRA DUO & HYDRA TRIO multi-stage self-cleaning filters

Exclusive multi-stage filters with self-cleaning pre-filter, for dual and triple stage filtration/treatment.

Self-cleaning pre-filter with back-wash, and exclusive filter cartridges:

- RAH stainless steel net cartridge at 90 micron.
- RLH plastic net cartridge at 90 micron.
- RSH pleated plastic net cartridge at 50 micron.

Cartridges for second and third stage available from the wide range of Atlas Filtri cartridges.

Models for 10" cartridges, IN/OUT connections 1/2", 3/4", 1", with brass or plastic BSP threads; models with NPT plastic threads 3/4", 1".

Housings provided with Filter-Fit: special centering device for SX cartridges.

All models provided with a drain funnel to protect potable water from back-flow, in compliance with UNI EN 1717-11/2002.

Accessory included: Filter-Fit.

Accessories on demand: brass and plastic nipples, spanner, wall brackets, KIT AUTO (discharge automation kit), Lubrikit.

Main materials: reinforced PP, PET.



HYDRA DUO HYDRA TRIO

HYDRA DS self-cleaning filters

Self-cleaning filters with back-wash provided with 360° rotational connection group for easy connection to horizontal or vertical pipes.

- Available in two versions with BSP IN/OUT male connections, flow rates from 3000 to 6000 l/h:
- HYDRA DS MP models with rotational group made from high-strength plastic, resulting from Atlas Filtri R&D for performing materials and innovative manufacturing processes. HYDRA DS MP are provided complete with 3/4" and 1" nipples (HYDRA DS MP 3/4+1).
 - HYDRA DS MO models with rotational group made from brass. Models with 3/4" nipples (HYDRA DS MO 3/4) or with 1" nipples (HYDRA DS MO 1).
- Models with exclusive filter cartridges:
- RAH models with stainless steel net cartridge at 90 micron.
 - RLH models with plastic net cartridge at 90 micron.
 - RSH models with pleated plastic net cartridge at 50 micron.
- All models provided with a drain funnel to protect potable water from back-flow, in compliance with UNI EN 1717-11/2002.
- Accessory included: spanner.
- Accessories on demand: KIT AUTO (discharge automation kit), Lubrikit.
- Main materials: reinforced PP, PET.



QR code
SEE TUTORIAL



EXCLUSIVE HYDRA FILTER CARTRIDGES

Flat seal with Antimicrobial Product Protection technology



RAH stainless steel net cartridge, filtration at 90 micron.
RAH HOT stainless steel net cartridge, filtration at 90 micron.
RLH plastic net cartridge, filtration at 90 micron.
RSH pleated plastic net cartridge, filtration at 50 micron.



All cartridges are provided with dedicated STAINLESS STEEL AISI 316 CARTRIDGE SPRING

RANGE OF PRODUCTS

DP FILTER HOUSINGS

Mono, Duo and Trio patented and registered models. Housings suitable with both standard SX flat seals (DOE) and BX quick-fit double o-ring end cap.

Housings provided with Filter-Fit: special centering device for SX cartridges.

IN/OUT connections 1/4", 3/8", 1/2", 3/4", 1", 1-1/4", 1-1/2" with brass or plastic BSP threads; models with NPT plastic threads 1/4", 3/4", 1".

Cartridge heights 5", 7", 10", 20". Models with transparent (TS) or opaque (AB-blue, BW-white) bowls. M models with 2 manometers. S models 10" and 20" with drain valve, provided with a funnel to protect potable water from back-flow, in compliance with UNI EN 1717 - 11/2002. MP models with plastic male IN/OUT connections BSP threads. Accessory included: Filter-Fit.

Accessories on demand: spanner, wall brackets, brass and plastic nipples, base (10" models only), KIT AUTO (discharge automation kit), Lubrikit.

Main materials: reinforced PP, PET.



SEE TUTORIAL



FILTER-FIT



Every DP filter housing is provided with Filter-fit, an Atlas Filtri specialty centering device which makes the SX (DOE) filter cartridges perfectly standing inside the housing; no more wrong positioning of the cartridge, no water by-passing, easier maintenance operations.

PATENTED



DP 10" MONO TS

DP 10" MONO AB

DP 10" MONO S M TS



DP 10" TRIO BW

DP 10" MONO BW



DP 10" DUO TS

DP 10" DUO AB

DP DS FILTER HOUSINGS

Housings with 360° rotational connection group for easy connection to horizontal or vertical pipes.

Available in two versions with BSP IN/OUT male connections:

- **DP DS MP models** with rotational group made from high-strength plastic, resulting from Atlas Filtri R&D for performing materials and innovative manufacturing processes. DP DS MP housings are provided complete with 3/4" and 1" nipples (DP DS MP 3/4+1).
- **DP DS MO models** with rotational group made from brass. Models with 3/4" nipples (DP DS MO 3/4) or with 1" nipples (DP DS MO 1). Suitable with both standard SX flat seals (DOE) and BX quick-fit

double o-ring end cap. Housings provided with Filter-Fit: special centering device for SX cartridges.

Cartridge heights 5", 7", 10", 20".

Models with transparent (TS) or opaque (AB-blue, BW-white) bowls. S models 10" and 20" with drain valve, provided with a funnel to protect potable water from back-flow, in compliance with UNI EN 1717 - 11/2002. Accessory included: Filter-Fit.

Accessories on demand: spanner, KIT AUTO (discharge automation kit), Lubrikit. Main materials: reinforced PP, PET.



DP DS 10" MP TS

DP DS 10" MO TS

DP DS 10" MP AB

DP DS 10" MP BW

QUALITY

INTERVIEW

«Whatever we do, we strive to do it well!»



Paolo Crocco
QUALITY, ENVIRONMENT
AND SAFETY MANAGER
AT ATLAS FILTRI

Here at Atlas Filtri, we believe in treating people well and in the importance of creating a friendly and safe workplace. This is why we're a BS OHSAS 18001:2007 and UNI EN ISO 9001:2008 certified company, adhering to high standards of occupational safety, human resource management and customer satisfaction.

This is a clear expression of our desire to be outstanding. What's more, the positive effects of these certifications spill over into the product as accreditation requires ongoing adherence to the principle of total quality for each and every filter, and this includes workplace safety.

ATLAS FILTRI EQUALS ENVIRONMENTAL RESPECT

At Atlas Filtri, each filter is produced in compliance with the principle of total quality, which includes being kind to the environment.

By seeking UNI EN ISO 14001:2004 certification, Atlas Filtri has positioned itself as an environmentally responsible manufacturer. We chose to achieve this high level of certification to demonstrate that environmental respect is a key component of our company's production and development process.

But there's more to it than that. Every day, adhering to this standard entails maintaining the environmentally friendly performance that got us certified in the first place. This effectively means we're required to reduce waste in all our production processes and ensure the responsible use of the company's assets and resources.



The Atlas Green badge you'll see on our products denotes our environmentally friendly practices, including our commitment to reducing greenhouse gases and using highly recyclable plastics.

ATLAS FILTRI is an active member in major world water organizations:

ASSOCIATA



ASSOCIAZIONE AQUA ITALIA

ASSOCIAZIONE COSTRUTTORI IMPIANTI E COMPONENTI PER IL TRATTAMENTO DELLE ACQUE PRIMARIE

FEDERATA



ANIMA

FEDERAZIONE DELLE ASSOCIAZIONI NAZIONALI DELL'INDUSTRIA MECCANICA VARIA ED AFFINE



QUALITY. NO QUESTION!

UNI EN ISO 9001:2008
quality management system

BS OHSAS 18001:2007
occupational health and safety management system

UNI EN ISO 14001:2004
environmental management system

PRODUCTS CERTIFICATIONS

Atlas Filtri's products are tested and certified under the most important procedures and standards worldwide:



TECHNOLOGY

Atlas Filtri equals AUTOMATION

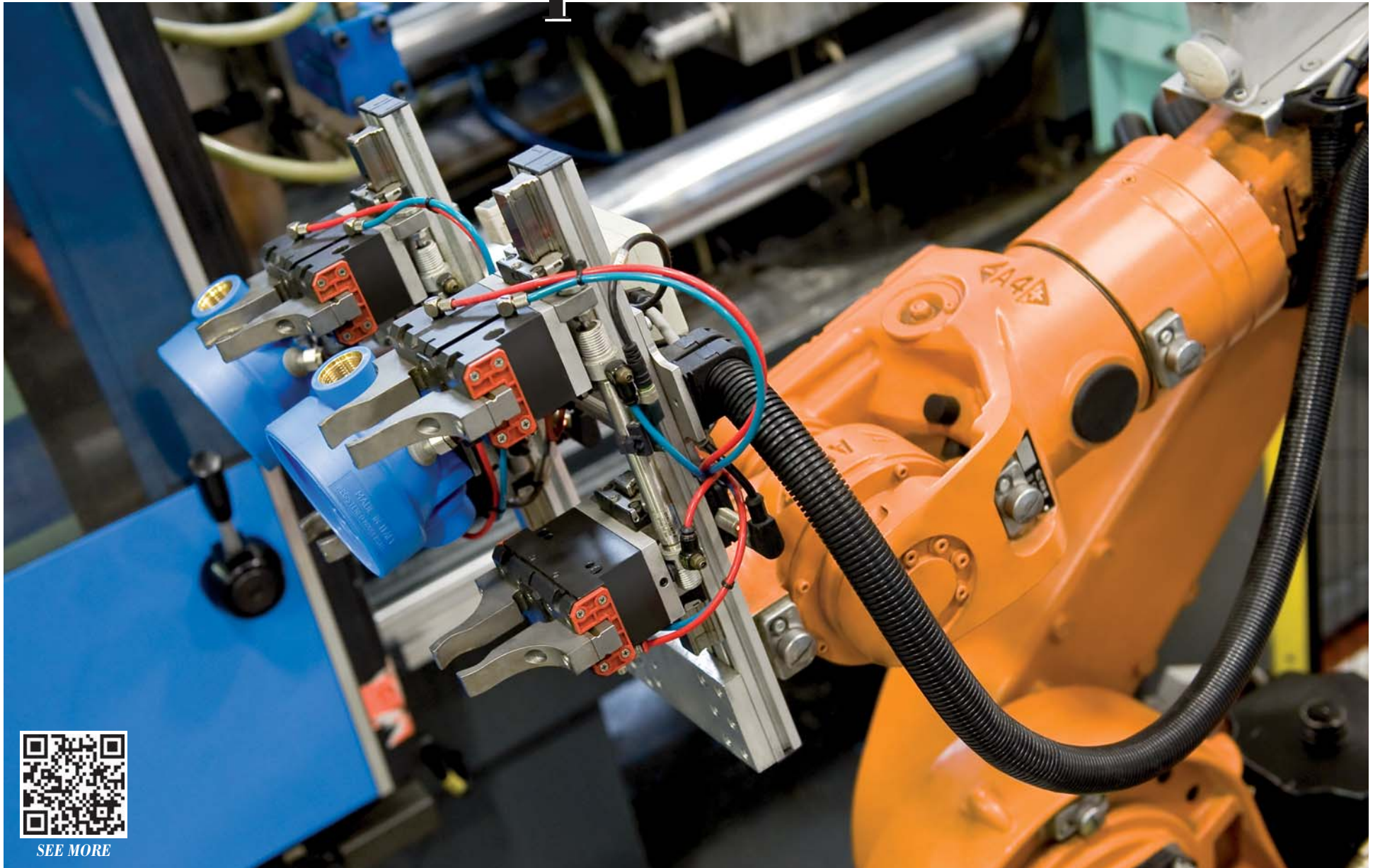

SEE MORE

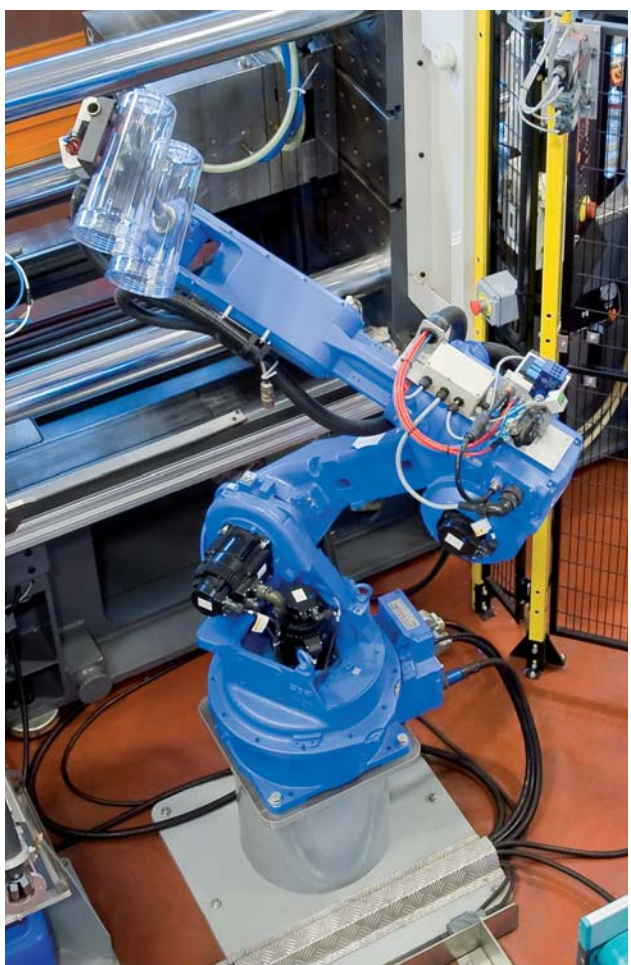

«Top technology employed at strategic points in our manufacturing process»

In our constant pursuit of total quality in the production of our filters and cartridges, we've opted to fully automate the manufacturing process. Atlas Filtri has been fitted out with an array of equipment to enhance manufacturing performance and boost production rates. In line with this policy, we've introduced highly automated machinery and systems at strategic points in the process to take manufacturing to new technological heights.

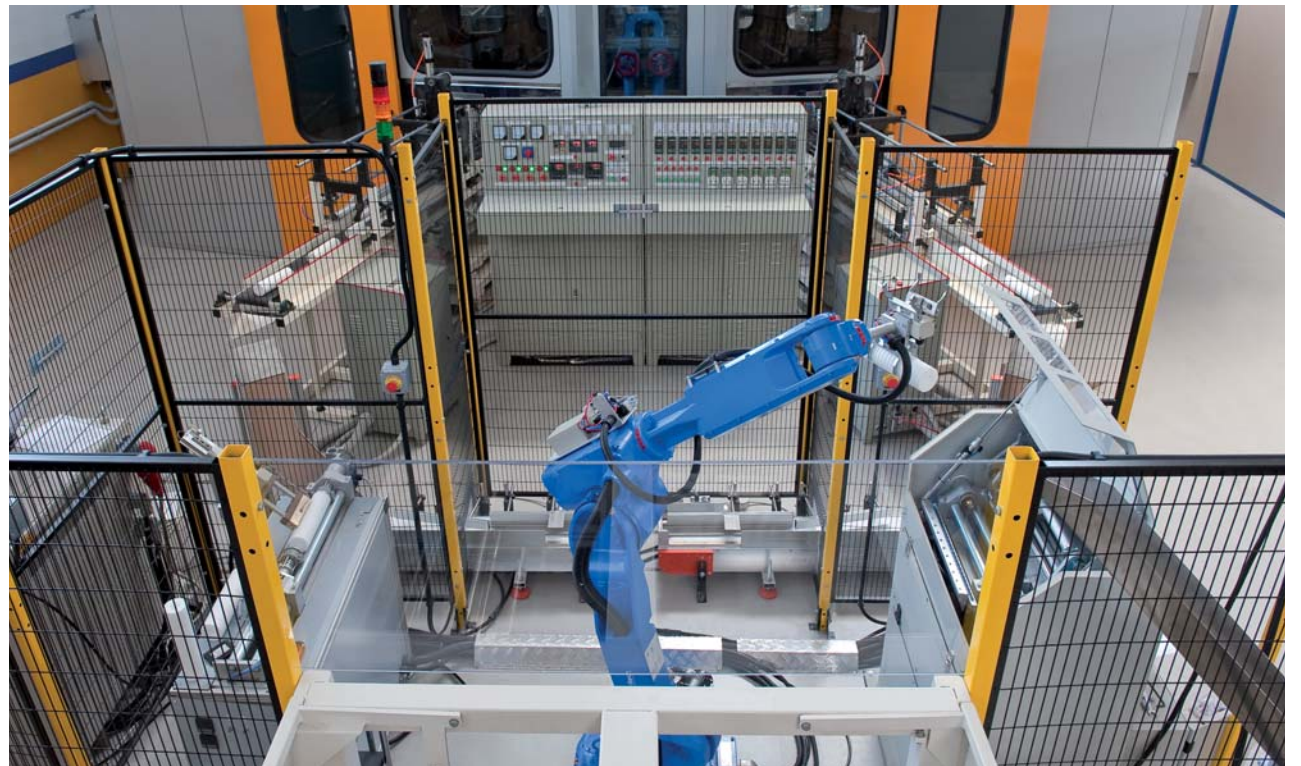

THE GROUP

“Success is doing things well!”



ATLAS FILTRI NEW HEADQUARTER



Fourty years of manufacturing have made Atlas Filtri the benchmark company for water filtration and treatment solutions, leader in the domestic and industrial sectors, marketing worldwide through a net of distributors in over 80 countries. The constant focus on quality and innovative processing technologies have made Atlas Filtri the reliable partner for everyone who engage in the mission of excellence in water treatment. The ability in quickly understanding the market needs allows Atlas Filtri in a continuous proposition of new solutions, by improving and innovating its own products and processes and by introducing year by year new products and services.

The Atlas Filtri group, made up of Atlas Filtri srl (production site and export) and Atlas Filtri Italia srl (distribution in Italy) with its division Atlas Filtri Engineering (water treatment plant design and production) can today respond to every request in the sectors of **WATER FILTRATION, TREATMENT, MICRO and ULTRA FILTRATION, REVERSE OSMOSIS, POTABILIZATION.**

With that background Atlas Filtri performs the most extensive range of products in the water filtration and treatment sector, for domestic and industrial use, with: **filter housings, filter cartridges, self-cleaning filters, anti-scale units, portable filters, drinking water filters, RO units, softeners, media filters, U.V. lamp sterilization, water treatment full plants, dosing pumps, chemical products.**

Research and development, process and product innovation are the major strategic issues today for Atlas Filtri. Due to that, the continuous research for new materials, new molding methods and expertise, the implementation of fully robotized lines, anyway open and flexible, the wide range of models and solutions, yet easy to be integrated for specific requests, lead us to offer the maximum for: **productivity, reliability, flexibility, brand consolidation, OEM and custom solutions.**



Daniele Costantini
VICE-PRESIDENT
OF ATLAS FILTRI

**ATLAS FILTRI, A STEERING FORCE
BEHIND THE WATER
TREATMENT INDUSTRY**

«We want people the world over to value us for who we are»



Andrea Costantini
PRODUCT
MANAGER
AT ATLAS FILTRI

**ATLAS FILTRI EQUALS
MATERIALS YOU CAN TRUST**

«We relish the daily challenge of coming up with solutions that make our products perfect»



Damiano Moro
TECHNICAL
DIRECTOR
AT ATLAS FILTRI

**ATLAS FILTRI, BEHIND OUR BRAND
LIES AN IMPRESSIVE BUSINESS**

«Our current growth dictates an imperative course of action: teaming product focus and business flair with the solidity of an industrialized group boasting a truly global reach»

INTERVIEW



**ATLAS FILTRI,
PASSION
AND ENTHUSIASM**

«We do what we do every day because we love doing it!»

Giovanni Costantini
PRESIDENT OF ATLAS FILTRI

Whether we're looking for just the right material for our filters, working out the best way to market a new product or liaising with a customer or supplier, there are two distinguishing traits that always set us apart: our enthusiasm and drive.

I love my job and you'd be hard pressed to find someone more passionate about what they do.

I'm 100% committed to seeing this group grow and that takes heart, brains and that most vital of basic ingredients, enthusiasm.

Looking back over Atlas Filtri's last twenty years of business, not a day's gone by where I didn't feel that drive: a quality that's been our hallmark from the very first moment I decided to enter the water treatment business.

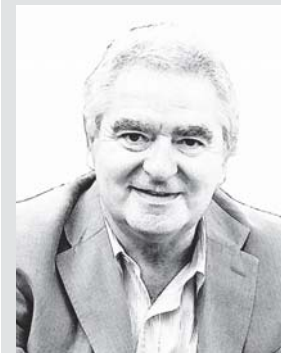

**ATLAS FILTRI ITALIA,
ITALY'S VERY OWN
SOLUTION PROVIDER**

«The people who work here are family»

Giorgio Moro
PRESIDENT OF
ATLAS FILTRI ITALIA

Intered the water treatment business when nobody else in Italy was concerned with the issue and there was a complete lack of knowledge surrounding filtration. Today, Atlas Filtri Italia - the Italian component of the Atlas Filtri group - is a stand-out player in the water treatment industry for two simple reasons: one, people know they can rely on our technologically superior filters; and two, even in a fragmented market like Italy, we're still your best choice for quick answers and solutions. Our industry is growing all the time: whether you want to improve water quality or have a treatment problem to solve, we can help. The fact that from 2012 to 2014 I've been holding the position of chairman of "Associazione Aqua Italia" is a further point of pride for our whole group: this is the Italian association of companies manufacturing plants, chemicals, accessories and components for the treatment of primary water for domestic, commercial and industrial use."



HIGHLIGHTS

OASIS DP

UNDER-SINK REVERSE OSMOSIS UNITS

OASIS DP are especially designed for the installation under the kitchen sink, complete with installation kit. All OASIS DP are based on a standard 6 stages unit, made up of: 3 pre-filtration stages, RO membrane stage, G.A.C. activated carbon post-filter stage, re-mineralizer post-filter stage.

The units are available in 2 main versions:

- OASIS DP with metal wall bracket, available in 4 models:

- OASIS DP STD - standard 6 stages unit.
- OASIS DP PUMP - standard 6 stages unit with booster pump.
- OASIS DP UV - standard 6 stages unit with UV lamp.
- OASIS DP PUMP-UV - standard 6 stages unit with booster pump and UV lamp.

- OASIS DP-F with metal frame, available in 2 models:

- OASIS DP-F PUMP - standard 6 stages unit with booster pump.
- OASIS DP-F PUMP-UV - standard 6 stages unit with booster pump and UV lamp.

COMPONENTS FOR UNDER-SINK UNITS



Housings DP Mono, Duo and Trio patented and registered models, for both cartridges with standard SX flat seals (DOE) and for cartridges with BX quick-fit double o-ring end cap. IN/OUT connections 1/4" and 3/8" with plastic BSP or NPT threads. Housings provided with Filter-Fit: special centering device for SX cartridges.

For cartridge heights 5", 7", 10".

Models with transparent (TS) or opaque (BW-white) bowls.

Accessories on demand: spanner, wall brackets, Lubrikit.

Main materials: reinforced PP, PET.



RO Vessel for 1812 and 2012 Reverse Osmosis membranes, with double o-ring sealing.

IN/OUT connections 1/8" with plastic BSP threads.

Accessories on demand: spanner, Lubrikit.

Main material: reinforced PP.



OASIS DP RO STD

OASIS DP RO PUMP

OASIS DP-F RO PUMP

with **DEDICATED PACKAGING!**
for EVERY MODEL >



> OASIS DP RO
Cartridges
replacement kit

Ask for original replacement filter cartridges and grant your OASIS DP RO unit the best performances.

- STAGE 1: Sediment filter 5 micron
- STAGE 2: CTO Granular Activated Carbon (G.A.C.)
- STAGE 3: CTO Carbon Block filter 5 micron



HIGHLIGHTS



ANTIMICROBIAL COMPONENTS FOR UNDER-SINK UNITS

DP Mono, Duo and Trio SANIC with Antimicrobial Product Protection technology, patented and registered housings for both cartridges with standard SX flat seals (DOE) and for cartridges with BX quick-fit double o-ring end cap. IN/OUT connections 1/4" and 3/8" with plastic BSP or NPT threads. Housings provided with Filter-Fit: special centering device for SX cartridges. For cartridge heights 5", 7", 10". Models with transparent (SANIC) or opaque (SANIC BG-grey) bowls. Accessories on demand: spanner, wall brackets, Lubrikit. Main materials: reinforced PP, PET with antimicrobial technology.



RO Vessel SANIC for 1812 and 2012 Reverse Osmosis membrane housing with double o-ring and Antimicrobial Product Protection technology. IN/OUT connections 1/8" with plastic BSP threads.

Accessories on demand: spanner, Lubrikit.
Main material: reinforced PP.



> OASIS DP SANIC RO Cartridges replacement kit



Ask for original replacement filter cartridges with Antimicrobial Product Protection and grant your OASIS DP SANIC RO units the best performances.

STAGE 1: Sediment filter 25 micron
STAGE 2: Sediment filter 5 micron
STAGE 3: CTO Carbon Block filter 5 micron

OASIS DP SANIC

UNDER-SINK ANTIMICROBIAL REVERSE OSMOSIS UNITS

OASIS DP SANIC is a range of RO units made up with patented and registered DP TRIO SANIC filter housings and with RO VESSEL SANIC, exclusive reverse osmosis membrane housing with double o-ring, featuring Antimicrobial Product Protection provided by silver-based technology which prevents the growth of stain and odor causing bacteria, keeping the unit cleaner for longer.

OASIS DP SANIC are especially designed for the installation under the kitchen sink, complete with installation kit. All OASIS DP SANIC are based on a standard 6 stages unit, made up of: 3 pre-filtration stages, RO membrane stage, G.A.C. activated carbon post-filter stage, re-mineralizer post-filter stage.

The units are available in 2 main versions:

- **OASIS DP SANIC with metal wall bracket, available in 4 models:**
OASIS DP SANIC STD - standard 6 stages unit.
OASIS DP SANIC PUMP - standard 6 stages unit with booster pump.

OASIS DP SANIC UV - standard 6 stages unit with UV lamp.
OASIS DP SANIC PUMP-UV - standard 6 stages unit with booster pump and UV lamp.

- **OASIS DP-F SANIC with metal frame, available in 2 models:**
OASIS DP-F SANIC PUMP - standard 6 stages unit with booster pump.
OASIS DP-F SANIC PUMP-UV - standard 6 stages unit with booster pump and UV lamp.

●●●● HUMOR ●●●●

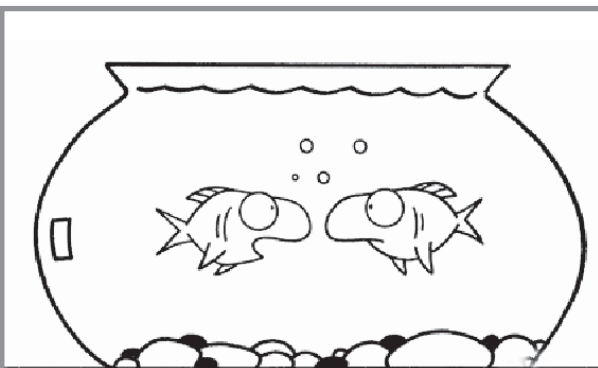

I DON'T KNOW WHAT CAUSES GLOBAL WARMING, BUT I'VE NOTICED IT ALWAYS GETS A LOT WARMER WHEN I PEE...

HIGHLIGHTS

POLYPHOSPHATE DOSING SYSTEMS

ACADEMY

ANTI-SCALE CONDITIONING



Calcareous scale is caused by the presence of calcium and magnesium salts dissolved in water in the form of soluble bicarbonates.

Through the effect of heat, these salts are transformed into insoluble carbonates and tend to agglomerate as crystals, forming calcareous scale on the surface of pipes, coils and storage tanks used for the production of hot water for domestic or industrial use.

Over time, the scale obstructs pipes and forms thick encrustations in heating systems. This leads to inefficiency and to a drastic reduction in energy output, as well as to high servicing and maintenance costs.

ANTI-SCALE TREATMENT WITH POLYPHOSPHATES

Polyphosphate treatment is a simple, effective and economic solution for the problem of scale deposits. When dissolved in water, the polyphosphate prevents the formation of calcium carbonate encrustation by acting upon its crystallization, without affecting the hardness of the water. Over time, it also tends to break down existing deposits. Polyphosphates also provide effective protection against corrosion by creating a thin protective film on the surface of the pipes, coils and water heaters.



SEE TUTORIAL

- Proportional dosing systems with polyphosphate crystals **DOSAPROP** and **DOSAPROP-HA**.

- Proportional dosing systems with polyphosphate powder or ready-to-use refill **DOSAPLUS**.

Proportional dosing systems are designed for household use for the treatment of drinking water in compliance with UE Directive 98/83/CE.



Proportional dosing system equipped with device providing "Venturi" effect, dosing polyphosphate in compliance with UE Directive 98/83/CE for drinking water.

- Non-proportional dosing systems with polyphosphate crystals **DOSAFOS**, **DOSAFOS-HA**, and **DOSAL**.

Non-proportional dosing systems are designed for "technical" applications which are not intended to provide drinking water.

ANTI-SCALE TREATMENT WITH MAGNETIC SYSTEMS

The water is conditioned using a magnetic field which modifies the structure of the calcium and magnesium salt crystals, preventing the formation of calcium carbonate encrustations. It does not alter the hardness of the water or its salt content.

Magnetic anti-scale systems **MAG conditioners**.

MAG are designed for household use for the treatment of drinking water in compliance with UE Directive 98/83/CE.

RANGE OF PRODUCTS

DOSAPROP PLUS

DOSING SYSTEMS WITH POLYPHOSPHATE CRYSTALS



DOSAPROP CADET PLUS 2P DOSAPROP MEDIUM PLUS 3P DOSAPROP JUNIOR PLUS 3P DOSAPROP JUNIOR PLUS 2P DOSAPROP SENIOR PLUS 3P DOSAPROP SENIOR PLUS 2P

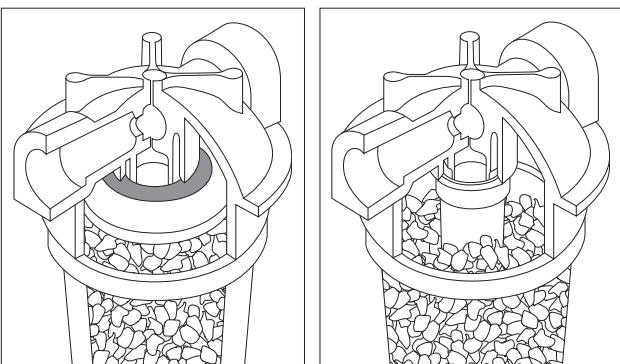

PLUS HA MODELS
with REPLACEMENT CARTRIDGE

PLUS MODELS
with LOOSE CRYSTALS

Proportional dosing systems, designed for the maximum polyphosphate release of 5 mg/l. In compliance with UE Directive 98/83/CE for use in drinking water.

Models with loose crystals and diffuser tube (DOSAPROP) and with polyphosphate cartridge (DOSAPROP HA). IN/OUT connections 1/2", 3/4", 1", with brass BSP threads. 3P and 2P models, heights 4", 5", 7", 10".

MIGNON models with -S- 90° connections and -L- in-line connections designed for point of use applications (boilers). Accessories on demand: spanner, wall brackets, brass and plastic nipples, Lubrikit.

Main materials: reinforced PP, PET, SAN (only Mignon type).

DOSAFOS PLUS

DOSING SYSTEMS WITH POLYPHOSPHATE CRYSTALS

Non-proportional dosing systems designed for the use on not-for-drinking water applications.

Models with loose crystals and diffuser tube (DOSAFOS) and with polyphosphate cartridge (DOSAFOS HA). IN/OUT connections at 1/2", 3/4", 1", with brass or plastic BSP threads;

models with NPT plastic threads 3/4", 1". 3P and 2P models, height 4", 5", 7", 10".

MP models with plastic male IN/OUT connections BSP threads.

MIGNON models with -S- 90° connections, -L- in-line connections and -SL- 3 ports heads connections designed for point of use applications (boilers).

Accessories on demand: spanner, wall brackets, brass and plastic nipples, Lubrikit.

Main materials: reinforced PP, PET, SAN (only Mignon type).



DOSAFOS SENIOR PLUS 3P MP

DOSAFOS SENIOR PLUS 3P

DOSAFOS JUNIOR PLUS 2P

DOSAFOS MIGNON SL PLUS 3P

DOSAFOS MIGNON S PLUS 2P

REFILLS



Polyphosphate crystals refill
0,5 kg and 1,5 kg pack with 6/10 (small) crystals or 10/20 (large) crystals, for refill of DOSAPROP, DOSAFOS, DOSAL.



HA polyphosphate cartridge refill
for DOSAPROP HA and DOSAFOS HA, heights 4", 5", 7", 10".

HA MIGNON polyphosphate cartridge refill
for DOSAPROP MIGNON HA and DOSAFOS MIGNON HA, height 5" M.



Polyphosphate crystals 160 g blister
for refill of DOSAL

ANTI-SCALE | ANTI-CORROSION

Dosapump LP is designed for the anti-scale and anti-corrosion protection of boilers and water heaters.

PROTECT YOUR BOILER!



360°

DOSAPUMP LP is the rotary gear pump for the proportional dosage of liquid polyphosphate, based on a new concept from Atlas Filtri:

- hydraulically operated, no power required;
- self-priming, by simply adding liquid polyphosphate POLIPHOS LP into the tank when it lowers down to minimum, with no re-starting or cleaning operation, no by-passing required for maintenance or in case of counter-pressure from the hydraulic network;
- made up of 2 main separable parts, the pump and the tank, which can be jointly or separately installed removing the pump from the tank, for the installation in case of restricted space availability;
- orientable IN/OUT connections, which can be horizontally or vertically oriented by simply rotating the pump within its frame: no disassembly required;
- reduced dimensions.

IN/OUT connections at 1/2" male with plastic BSP threads.

Dosage (as P2O5): 3 mg/l.

Liquid polyphosphate refill: POLIPHOS LP.

PATENT PENDING

DOSAL

DOSING SYSTEMS WITH POLYPHOSPHATE CRYSTALS

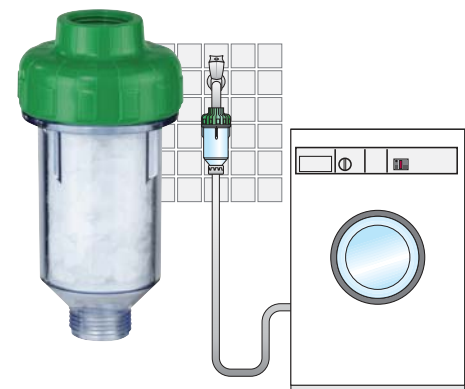

Non-proportional dosing system designed for the protection of washing machines.

Easy and ready for the installation to standard water supply of washing machines. No plumbing required.

Accessory on demand: Lubrikit.

Main materials: reinforced PP, SAN.

RANGE OF PRODUCTS

DOSING SYSTEMS WITH POLYPHOSPHATE POWDER



SEE TUTORIAL



DOSAPLUS 2

DOSAPLUS 3

DOSAPLUS 4

DOSAPLUS 5-6

DOSAPLUS 7

DOSAPLUS

Proportional dosing systems, designed for the maximum polyphosphate release of 5 mg/l. In compliance with UE Directive 98/83/CE for use in drinking water.

All models provided with 360° rotational group for the easy connection to horizontal or vertical pipes.

- **DOSAPLUS 2** with brass head and brass rotational group IN/OUT 1/2" BSP male. Mixing/by-pass valve integrated.
- **DOSAPLUS 3** with plastic head and brass rotational group IN/OUT 1/2" BSP male. By-pass valve integrated.
- **DOSAPLUS 4** with plastic head and brass rotational group IN/OUT 1/2" BSP male.
- **DOSAPLUS 13** with plastic head and plastic rotational group IN/OUT 1/2" BSP male. By-pass valve integrated.
- **DOSAPLUS 14** with plastic head and plastic rotational group IN/OUT 1/2" BSP male.
Accessory included: spanner.
Accessories on demand: adaptor for boilers, Lubrikit.
Polyphosphate refill: ready-to-use refill POLIPHOS A in package with 12 refills or in skinpack with 2 refills.
Main materials: brass, reinforced PP, SAN.

- **DOSAPLUS 5** with plastic head/brass rotational group IN/OUT 3/4" BSP male.
- **DOSAPLUS 6** with plastic head/brass rotational group IN/OUT 1" BSP male.
- **DOSAPLUS 7** with special plastic rotational group IN/OUT, provided with 3/4" and 1" BSP nipples. The rotational group is made of high-strength plastics, resulting from Atlas Filtri research for performing materials and innovative manufacturing processes.
Accessory included: spanner.
Accessory on demand: Lubrikit.
Polyphosphate refill: ready-to-use refill POLIPHOS B.
Main materials: brass, reinforced nylon, reinforced PP, PET.



POLIPHOS A
REFILL FOR DOSAPLUS 2-3-4-13-14



POLIPHOS B
REFILL FOR DOSAPLUS 5-6-7

DOSAPLUS 13-14

POLYPHOSPHATE PROPORTIONAL DOSING SYSTEMS with plastic head and plastic rotational group

ANTI-SCALE



DOSAPLUS 13



DOSAPLUS 14



prodotto conforme a
D.M.
25/2012

ATLAS FILTRI
improving water

WORLD NEWS

**If you wanna go big
the name is DP BIG, Atlas Filtri DP BIG.**

**DP BIG DUO &
DP BIG TRIO**

The one and only manifold housings for 4.5" cartridges in the market



SEE MORE

safer, easier, faster. Patented.

DRINKING WATER SYSTEMS



IMPROVING WATER

Atlas Filtri range of filter housings designed for the installation at Point-Of-Use, under the kitchen sink or over the counter top, complete with installation kit and dedicated faucets. A complete range of sediment and treatment filter cartridges makes housings suitable for every POU requirements. Dedicated to the improvement of drinking water.

BRAVO DP BRAVO DP CASE under-sink filter housings

Mono, Duo and Trio patented and registered models. Filter housings designed for the installation under the kitchen sink. For both cartridges with standard SX flat seals (DOE) and for cartridges with BX quick-fit double o-ring end cap. Housings provided with Filter-Fit: special centering device for SX cartridges. Cartridge heights 10". Portable model BRAVO DP CASE with TRIO filter housing in a plastic case with easy connection kit. Accessories included: spanner, wall brackets, Filter-Fit, installation kit. Accessories on demand: standing base, Lubrikit. Main materials: reinforced PP, PET.



DEPURAL® mobile filter housings

Patented mobile filter housings especially designed for the counter-top.

Complete with universal tap adaptor and installation kit. DEPURAL® and DEPURAL® Duplex models, for 10" cartridges with standard SX flat seals (DOE).

Accessories included: standing base, wall bracket (Depural BS), installation kit. Accessories on demand: spanner, wall bracket (Depural® Duplex), installation kit with diverter valve, Lubrikit. Main materials: PP, polystyrene.



DEPURAL® TOP mobile filter housings

Mobile filter housings especially designed for the counter-top.

Complete with tap diverter valve and installation kit. Single, DUO and TRIO models, for 10" cartridges with both standard SX flat seals (DOE) and BX quick-fit double o-ring end cap. DVB models with brass diverter valve. ECO models with plastic diverter valve. Models with transparent (TS), opaque (BW-white) and chrome plated (CH) bowls. Accessories included: spanner, installation kit. Accessories on demand: Lubrikit. Main materials: PP, SAN, ABS.



DEPURAL® DP CASE portable filter housings



Enjoy the portability of a Depural DP unit with DP Trio housing, complete with connection kit and faucet.

DEPURAL® DP mobile filter housings

Mobile filter housings designed for the counter-top. Complete with universal tap adaptor and installation kit.

MONO, DUO and TRIO patented and registered models, for cartridge heights 5", 7", 10" with both standard SX flat seals (DOE) and BX quick-fit double o-ring end cap.

All models provided with Filter-Fit: special centering device for SX cartridges.

Models with transparent (TS) or opaque (BW-white) bowls. Accessories included: standing base (only 10" models), spanner, wall brackets, Filter-Fit, installation kit.

Accessories on demand: Lubrikit.





Main materials: reinforced PP, PET.



IN-LINE housings with dedicated filter cartridges

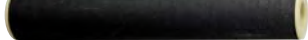

In-line Filter Housing with double o-ring sealing. Fit to special cartridges with proprietary design of end caps and sealing. Suitable for applications on refrigerators, drinking water fountains, water coolers. IN/OUT connections 1/4" and 1/8" with plastic BSP or NPT threads. Accessories on demand: installation kit, spanner, clips, Lubrikit. Main material: reinforced PP.

-  CPP IN-LINE MELT-BLOWN PP CARTRIDGE
-  HA IN-LINE POLYPHOSPHATE CRYSTALS CARTRIDGE
-  P IN-LINE FILLABLE EMPTY CONTAINER
-  LA IN-LINE GRANULAR ACTIVATED CARBON (GAC) CARTRIDGE
-  CA-SE IN-LINE CARBON-BLOCK CARTRIDGE

HIGHLIGHTS

ATLAS FILTRI LEVERAGES CUSTOMER BUSINESS



SERVICE ATLAS FILTRI



Atlas Filtri and Atlas Filtri Italia are committed in providing markets with products designed and manufactured by the dedicated Division Atlas Filtri Engineering, from softeners to RO units of all dimensions, to fully equipped drinking water plants, as well as any other specially designed water treatment plant. SERVICE is the division set to provide all the after-market which is necessary for the benefit of the Customers and Partners: from product design and sizing, to plant assembly and start-up, to unit maintenance and repair, the service can be tailor-made upon Customer requirements. A team of skilled staff is continuously trained on the latest water treatment technologies to properly satisfy those requirements.

ATLAS FILTRI EQUALS PURE ITALIAN STYLE

Italian style is recognized and revered the world over, that's the way of drawing attention to the high standards of design and manufacture that Atlas Filtri products are required to meet. Putting the Made in Italy stamp on each products means certifying the total quality and superior performance that come as standard with any Atlas Filtri item. Proud of this choice, Atlas Filtri gives the international market access to Italian expertise and flair. Everyone can be a part of it, just be an Atlas Filtri Partner and wear the "tricolor botton".

wear & feel

| Made in Italy |



Be an Atlas Filtri Partner
ask for the tricolor botton and wear true italian style.



Fashion | your | Water

INTERVIEW

MARKETINGplan



Stefano Campaioli
MARKETING DIRECTOR
AT ATLAS FILTRI

Atlas Filtri's communication is based on a main concept: every person who Workum here is always available, that's what makes our Company what it is. We put ourselves, our own face, with the aim to let people know who we are and how we do things. Our Communication is always direct and applies to all media we exploit: technical and commercial literature, Company profile and corporate presentation, training and seminars. We bring this approach also to the Exhibitions in which we participate, by building stands as a "landscape" of images which can make us visible and orientate visitors.

The future of Atlas Filtri's off-line marketing will be focused in further improving the direct communication approach so it can be immediately accessible for the market and consumers. To that regard new solutions will be soon adopted for commercial literature and packagings, later for all corporate communication.

On-line marketing is the new task in Atlas Filtri's Marketing Plan: we put a great commitment in the development of our Web-Marketing plan by designing a totally new Website and by introducing new resources specifically dedicated to an ambitious program of on-line marketing.

Atlas Filtri will be soon very active on social media, while the Youtube channel is already active with tutorial contents.

We expect great results from the market further to our on-line and off-line marketing plans. Customers and Partners will get a great number of promotional and tutorial contents and, in the short run, also contents and activities related to the Academy, the new service that improves knowledge and boost markets.

INTERVIEW

ACADEMY ATLAS FILTRI



Edoardo Masiero
R&D TECHNICAL SUPPORT
AT ATLAS FILTRI

Established as a service Division for Atlas Filtri and Atlas Filtri Italia, Academy applies with its own Logo conceived to grant immediate acknowledgment to Customers and Partners.

The new Division aim is to bring Atlas Filtri's and Atlas Filtri Italia's technical and commercial know-how to the market, set up a wider knowledge of water treatment related problems and thus a better understanding of products and services fit to the solution.

Academy offers training courses and seminars at Atlas Filtri's premises or at Customers' locations.

In future also on-line training courses and webinars will be available, thanks to the new Web Marketing Plan.

It is our strong belief that knowledge and competence are the drivers of success, for us as well as for our Partners.

WATER ON MARS!

WHEREVER YOU GO
WHATEVER WATER YOU GET
ATLAS FILTRI IS WITH YOU.



 **ATLAS FILTRI**®
improving water

ATLAS FILTRI s.r.l.

Headquarter: via Pierobon, 32 | Production site: via del Santo, 227
I-35010 Limena, Italy - Tel. +39.049.76.90.55 - Fax +39.049.76.99.94
www.atlasfiltri.com

ATLAS FILTRI, DEPURAL and SANIC are registered trade marks of ATLAS FILTRI srl.

Unauthorized use of the registered trade mark is strictly forbidden and legally persecuted.

Images and texts are property of ATLAS FILTRI srl, which reserves the rights to change products design and specification without prior notice.